

HARDENED SURFACES

HIGH PRECISION

STRONG MAGNETIC FORCE

MAGNETIC V-BLOCK

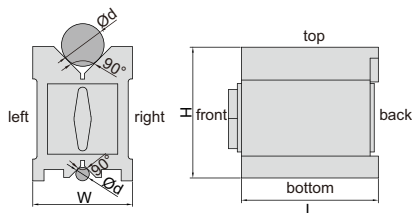

- Hardened, high accuracy, strong magnetic force, for grinding, light milling, drilling and inspection of round and square jobs
- All working surfaces are hardened to HRC60±2
- Magnetic force on top, bottom and two V grooves
- V groove on the top for large shafts
- V groove on the bottom for small shafts
- Suitable for cast iron surface plates and granite surface plates

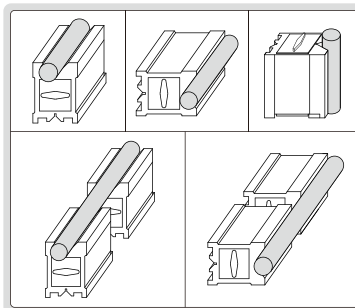

6889-11



6889-1

Individual

Code	Size (LxWxH)	Range of shafts (Ød)	Magnetic force	Parallelism of V groove to top, bottom, left, right sides	Squareness of V groove to back side
6889-11	75x56x75mm	5-40mm	75kgf	5µm	5µm
6889-22	100x70x95mm	5-65mm	100kgf	5µm	5µm
6889-33	150x75x100mm	5-70mm	125kgf	5µm	5µm
6889-44	200x124x150mm	10-140mm	175kgf	10µm	10µm

Matched pair

Code	Size (LxWxH)	Range of shafts (Ød)	Magnetic force	Parallelism of V grooves to top, bottom, left, right sides	Squareness of V grooves to back side	Height difference of a matched pair
6889-1	75x56x75mm	5-40mm	75kgf	5µm	5µm	5µm
6889-2	100x70x95mm	5-65mm	100kgf	5µm	5µm	5µm
6889-3	150x75x100mm	5-70mm	125kgf	5µm	5µm	5µm
6889-4	200x124x150mm	10-140mm	175kgf	10µm	10µm	10µm