

PRECISION UNIVERSAL VISE

- Horizontal rotary: range 360°, graduation 0.05°
- Vertical incline: range 45°, graduation 0.05°
- With vertical incline adjust knob
- Parallelism and squareness between A, B, C and D: 5μm/100mm, parallelism between D and E at 0°: 10μm/100mm
- Made of tool steel
- Hardness HRC56-58

Code	Jaw opening(Q)	Jaw width(W)
6521-80	0-80mm	70mm

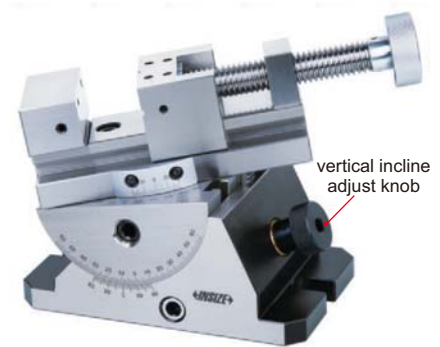
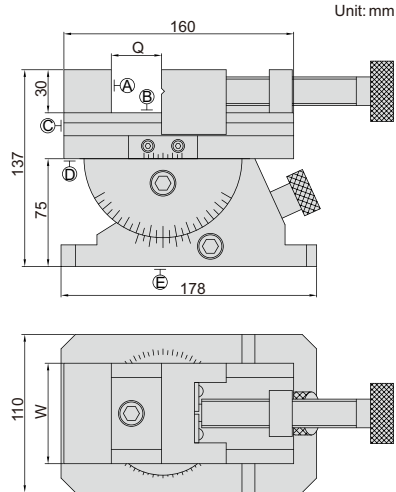

6521-80