

COMBINATION SQUARE SET

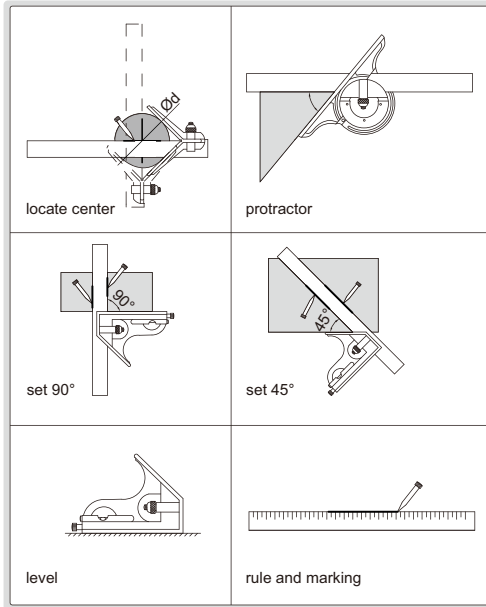

- Center head (made of cast iron):
To locate center of cylinder with diameter (\varnothing d): 30 - 100mm
Accuracy: ± 0.15 mm
- Protractor head (made of cast iron):
To set the blade at desired angle to an edge of a workpiece, and can be used to measure angles
Range: 0-180°
Accuracy: ± 7 min.
- Square head (made of cast iron):
To set the blade at 90° or 45° to an edge of a workpiece
Accuracy: ± 8 min for 90° square, ± 10 min for 45° square
- Blade (made of stainless steel):
Range: 300mm/12",
Graduation: 0.5mm and 1/32" on front face, 1mm and 1/64" on back face
- Optional accessory: rigid rule (code 7113)

Code	Remark
2278-2	2-piece set
2278-3	3-piece set
2278-180	4-piece set



2278-2



2278-3



2278-180

