

# THICKNESS GAGE

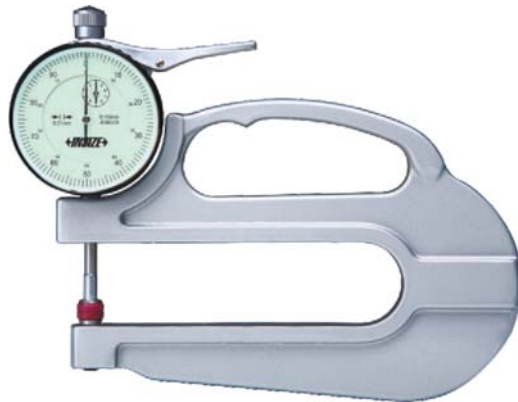
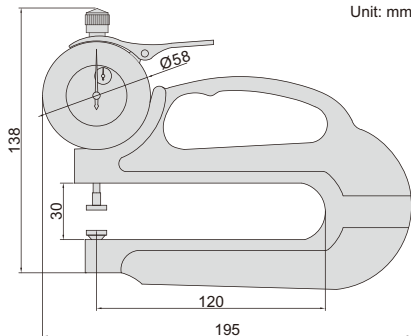
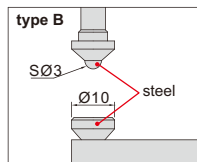
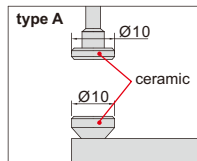

| Code     | Range  | Graduation | Accuracy | Type |
|----------|--------|------------|----------|------|
| 2365-10  | 0-10mm | 0.01mm     | ±0.02mm  | A    |
| 2365-20  | 0-20mm | 0.01mm     | ±0.03mm  | A    |
| 2365-10B | 0-10mm | 0.01mm     | ±0.02mm  | B    |
| 2365-20B | 0-20mm | 0.01mm     | ±0.03mm  | B    |

2365-10