

BACK PLUNGER LONG STYLI DIAL TEST INDICATOR

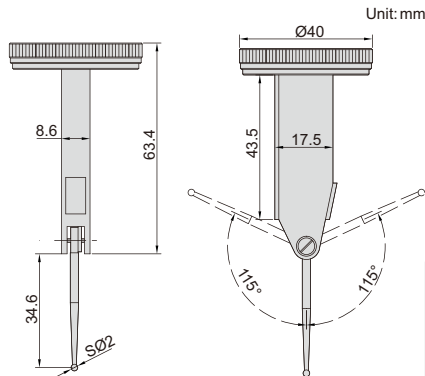

2899-05

- Ceramic bearing
- Anti magnetic carbide contact point
- Two measuring directions
- Supplied with one clamp: diameter Ø8mm
- Optional accessory: styli (page 106)



Unit: mm

ANTI MAGNETIC
CARBIDE CONTACT POINT

clamp

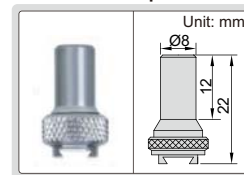

Code	Range	Graduation	Accuracy	Hysteresis	Dial reading
2899-05*	0.5mm	0.01mm	13µm	3µm	0-25-0

* Supplied with manufacturer inspection certificate traceable to NIST USA