

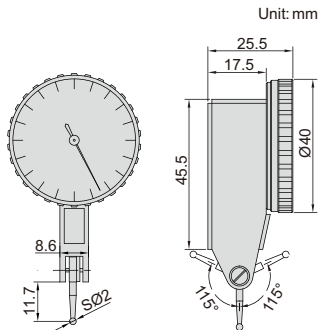

ANTI MAGNETIC  
CARBIDE CONTACT POINT

- Ceramic bearing
- Anti magnetic carbide contact point
- Two measuring directions
- Supplied with one clamp: diameter  $\varnothing 8\text{mm}$
- Optional accessory: styli (page 106)



Code	Range	Graduation	Accuracy	Hysteresis	Dial reading
2897-02 *	0.2mm	0.001mm	4 $\mu\text{m}$	2 $\mu\text{m}$	0-100-0

\* Supplied with manufacturer inspection certificate traceable to NIST USA

## PRECISION DIAL TEST INDICATOR



2897-02

