

LONG STYLI DIAL TEST INDICATOR



2896-05

- Ceramic bearing
- Anti magnetic carbide contact point
- Two measuring directions
- Supplied with one clamp:
diameter Ø8mm
- Optional accessory: styli (page 106)

Code	Range	Graduation	Accuracy	Hysteresis	Dial reading
2896-05*	0.5mm	0.01mm	13µm	3µm	0-25-0

* Supplied with manufacturer inspection certificate traceable to NIST USA

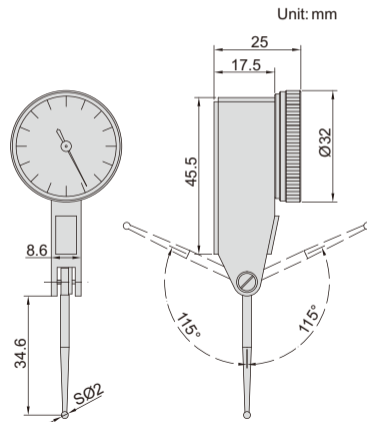

ANTI MAGNETIC
CARBIDE CONTACT POINT

