

# BORE GAGE

ATTENTION: NOT SUITABLE FOR 0.001MM DIAL INDICATORS

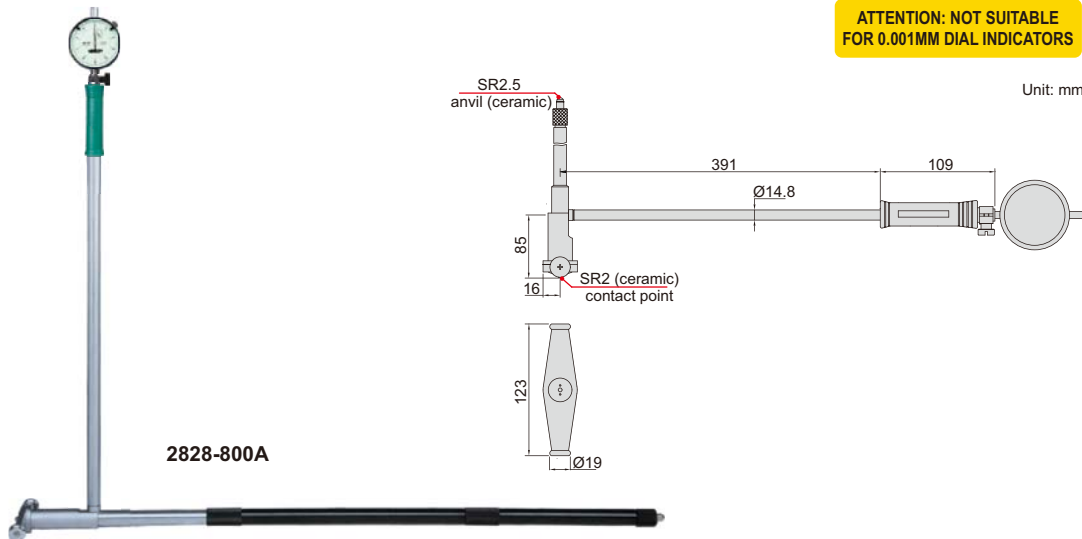

Code	Range	Indicator	Accuracy	Repeatability
2828-800A	400-800mm	dial indicator code 2308-10FA, range 10mm, graduation 0.01mm	±0.025mm	0.003mm